

BALL VALVES

SPECIFICATION

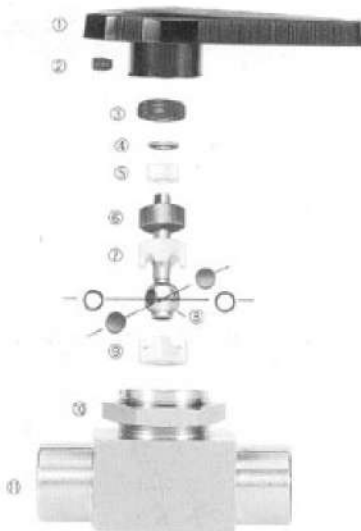

1. CONNECTION : AVLOK TUBE FITTING FEMALE THREAD
2. OPERATION TEMPERATURE : -10°C ~ +65°C (50°F ~ 150°F)
3. MAX OPERATION PRESSURE : ASTM A182 F316 : 3000 PSIG (206 BAR)
4. SIZE RANGE 1/8" UPTO 1"
5. AVAILABLE IN S.S. AND BRASS

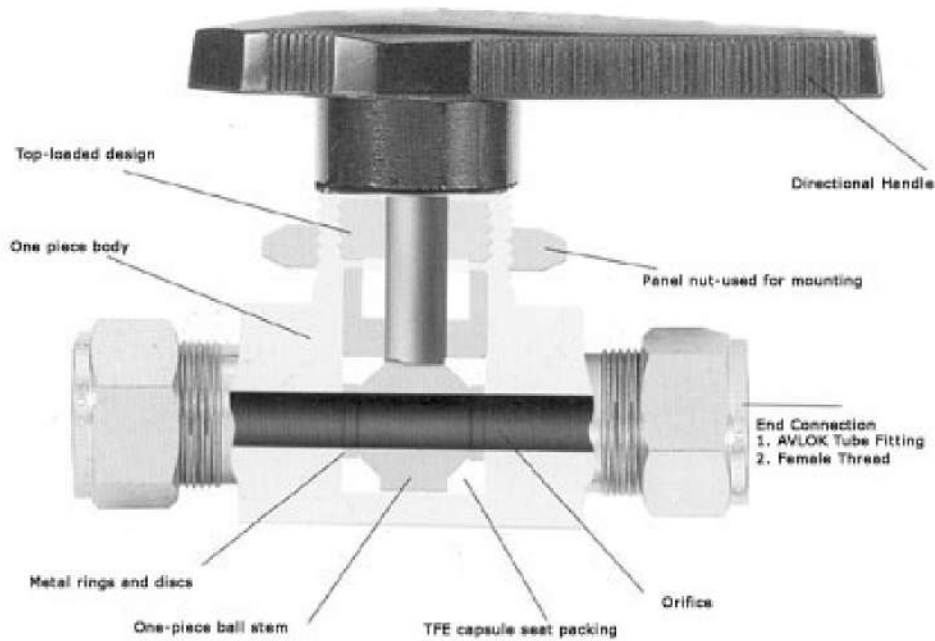

No.	Description	SS316
1.	Handle	Nylon
2.	Set Screw	Steel
3.	Packing Bolt	316SS
4.	Upper Gland	316SS
5.	Bushing	TFE
6.	Lower Gland	316SS
7.	Upper Packing	TFE
8.	Ball Stem	316SS
9.	Side Disk	316SS
10.	Lower Packing	TFE
11.	Panel Nut	304SS
12.	Body	316SS

Lubrication: Silicon base lubricant



All dimensions are for reference only, and are subject to change without prior notice.
 Sizes and types other than those featured above are available on request.